

Aspamet

SOLUTIONS FOR ENVIRONMENT TECHNOLOGY IN WATER

CRANE TYPE ZS

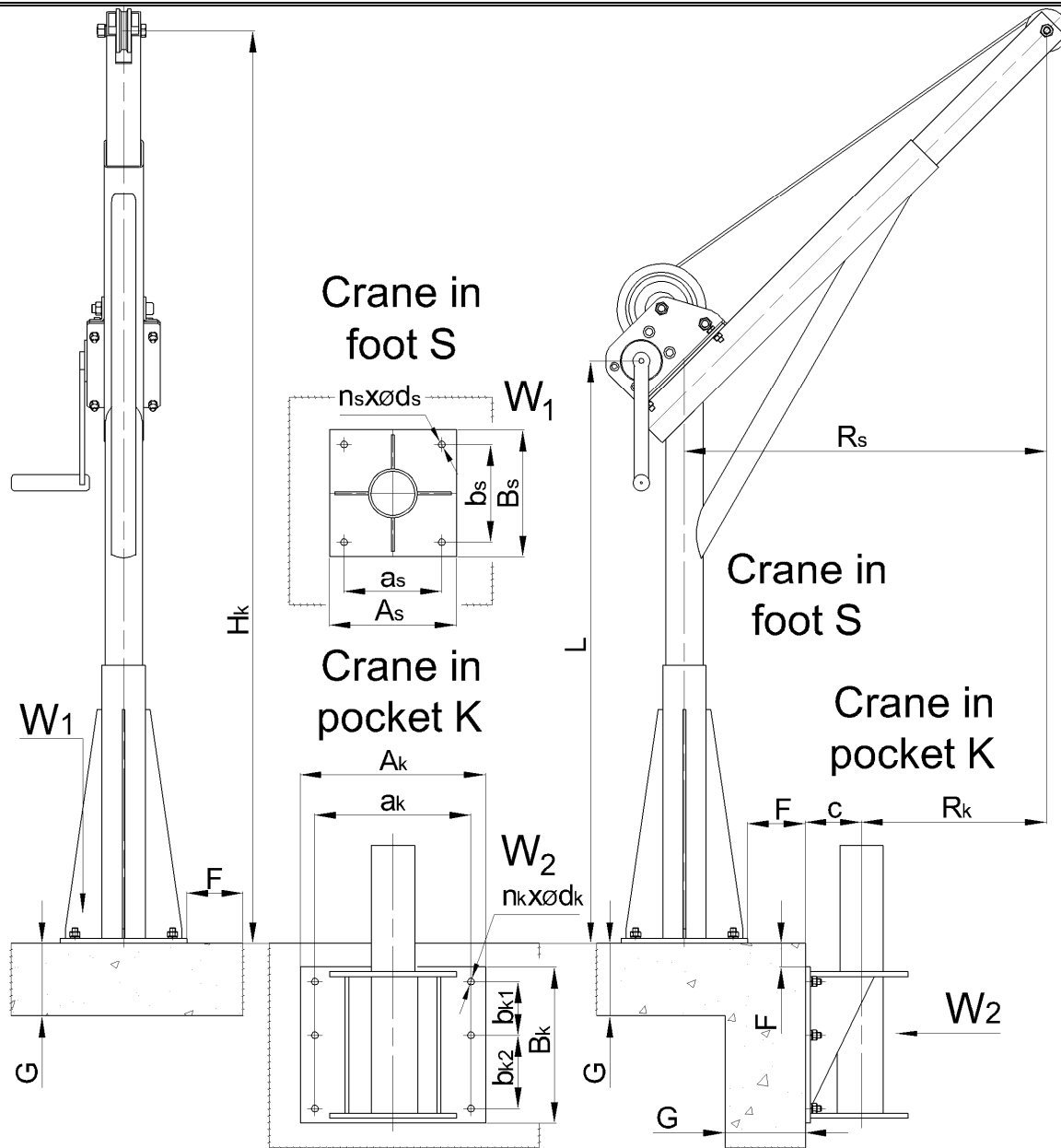

Type	H [mm]	R [mm]	L [mm]	Q [kg]	F _{min.} [mm]	G _{min.} [mm]	c [mm]	Concrete standard	*Mat.				
ZS15	1945-2440	600-1100	1425-1920	150	90	140	114	C16/20	OC, N				
ZS25	1945-2440	600-1100	1425-1920	250	90	140	114	C16/20	OC, N				
ZS40	2250-2750	900-1400	1425-1920	400	140	200	114	C16/20	OC, N				
Type	Crane in foot S						Crane in pocket K						
	A _s [mm]	a _s [mm]	B _s [mm]	b _s [mm]	Φd _s [mm]	n _s	A _k [mm]	a _k [mm]	B _k [mm]	b _{k1} [mm]	b _{k2} [mm]	Φd _k [mm]	n _k
ZS15	180	130	180	130	14	4	300	250	320	200 (b _{k1} + b _{k2})		14	4
ZS25	260	200	260	200	14	4	380	320	320	110	150	14	6
ZS40	320	260	320	260	22	4	380	320	320	110	150	22	6

*N – stainless steel; OC - galvanized

ZAKŁAD ODLEWNICZY "ASPAMET"; PRZEMYSŁOWA 4E STREET RAJSKO; 32-600 OŚWIĘCIM; POLAND